

impulse

Issue 1/2021

Employee and business partner magazine
ensingerplastics.com



Climate strategy

Renewable energy and material cycles increasingly important

Vaccines 6
Engineering plastics speed up production

LDS Technology 12
Alternative to silicon wafers

Copernicus space mission 16
TECASINT is the material of choice



Dear Reader,

There have been climatic fluctuations for as long as the earth has existed. In most cases, ice ages have alternated slowly with warm periods over several thousands of years. Life forms have been able to gradually adjust to the changes in the climate. Today, however, we are being confronted with rapidly advancing global warming which has been heavily influenced by us humans – with severe consequences for us and our environment. These can no longer be argued away and are forcing each one of us, whether in a private or public setting, to address the issues of climate protection and sustainability.

What does sustainability actually mean? Very different definitions of this exist, but they all have a common denominator, namely: meeting the needs of the current generation in such a way that the future generations are not in a worse position.

The things that initially spring to mind are usually saving energy, green electricity and electric vehicles. But the challenges are more multi-faceted than this, and our consumer behaviour has a critical role to play. One example is food, with meat production being particularly resource-intensive. Animals have to be fed for several years, and also they themselves generate gases which are harmful to the climate. In the Amazon Basin, umpteen hectares of rainforest are chopped down every minute just to produce the large quantities of cereal crops required for livestock farming. The textile industry is also a major contributor when it comes to excessive consumption of water

and energy – to say nothing of the poor working conditions in which seamstresses have to endure in some countries. In the mobility sector, too, even small changes in behaviour can have a big impact.

There are numerous starting points for changing our behaviour in a way that lasts. We all know from experience, however, how difficult it is for us to give up things we are used to – sometimes that seems absolutely unthinkable. But changes are possible! The ongoing pandemic, for example, has taught us this. Things that for a long time we thought impossible suddenly became doable. Thanks to video conferences, effective communication with customers, colleagues and business partners can be maintained without needing to travel. And mobile working can be productive, while eliminating the need to battle the commuter traffic every morning in the car.

In the future, climate protection and sustainability are going to be even more at the heart of Ensinger’s corporate actions. This will involve negotiating many tasks and challenges. But I am confident that together we are capable of achieving lots for us as a company, for society and for subsequent generations. Let’s go for it!

Yours,

Ralph Pernizsak

Ensinger presents climate strategy

Focus on renewable energy and material cycles

The manufacturing sector – particularly the plastics industry – has a key part to play in curbing climate change. With this in mind, the Ensinger Group’s owners and management team are acknowledging their responsibility when it comes to limiting and gradually reducing the company’s greenhouse gas emissions – in line with the requirements of the Paris Agreement on climate change.

As its first step, the climate strategy that has now been adopted envisages gaining a comprehensive overall picture of the company’s worldwide greenhouse gas (GHG) emissions. On the basis of this, Ensinger will – during the course of the current business year – decide on its reduction goals. Balancing and target setting shall take place in accordance with international standards. The intention is to submit the reduction goals to the Science-Based Target Initiative, an independent organisation for the targeted management of activities, and to have these approved. The GHG reduction measures derived from the targets chiefly address energy management and material resources. For example, the proportion of purchased and self-generated electricity that comes from renewable energies is to be increased step-by-step. In addition, more and more materials will be integrated into a material cycle.

Ensinger has already carried out some im-



Nufingen, Germany, is Ensinger’s headquarter. The manufacturing sector has a key part to play in curbing climate change.

portant spadework here, since a robust energy and environmental management system has long since been established. Working together with the company ClimatePartner, a CO₂ balance sheet covering two years has been prepared. The percentage of electricity obtained from renewable sources has been continuously increased, and at the Cham plant, a switch to green electricity is being made this business year, which will meet the entire power requirement. Similarly, the proportion of recycled material used and prepared in house has recently been significantly increased.



At the Cham site, the largest branch plant of the Ensinger Group, the entire electricity requirement will be switched to green electricity this business year.

Questions, suggestions, different opinions? Write to us at impulse@ensingerplastics.com

Imprint

Employee and business partner magazine

Ensinger GmbH
Rudolf-Diesel-Str. 8
71154 Nufingen
Tel. +49 7032 819 0
ensingerplastics.com

Publisher:
Dr. Oliver Frey
Ralph Pernizsak
Dr. Roland Reber

Editors:
Jörg Franke
Karin Skrodzki
Layout / Production:
Corinna Kohler

Cover photo:
Christian Schlüter
Printing:
Druckerei Maier,
Rottenburg



Photo: Shutterstock

As a member of the Management Board, Dr. Oliver Frey is responsible for developing the climate strategy at Ensinger. “We are confident that in a few years it will be possible for us to eliminate, worldwide, the company’s directly influenceable emissions. Our aim is to manage the company in a climate-neutral way, if possible without needing to use external offset schemes”, says Dr. Oliver Frey.

A pioneer in climate protection

Anyone who wants to conserve energy in buildings and thereby lower CO₂ emissions requires, among other things, highly insulating windows, doors and façades. A contribution is made here by the plastic insulbar® insulating profiles from Ensinger, which are used as thermal breaks between the inner and outer shells of aluminium frames. As early as 1977, Ensinger was a pioneer with the first series-produced thermal insulating bars for metal windows. In 2013, Ensinger was the first



Photo: KraussMaffei

Rottenburg-Ergenzingen is home to the Ensinger Group’s biggest injection moulding plant. The measures for reducing CO₂ emissions primarily address energy management and material resources. For example, the percentage of electricity obtained from renewable energies is to be gradually increased. In addition, more and more materials will be integrated into a material cycle.

manufacturer to launch a insulating profile made from recycled material: insulbar RE combines energy efficiency and sustainability. In the meantime, the portfolio has

been expanded to include insulbar RE-LI, a profile made of foamed, unmixed recycled PA 66.

Global commitment to sustainable management



Klaus Ensinger, Head of Staff Function Special Projects. From 1997 to 2021, he was a member of the executive board of Ensinger GmbH and the Ensinger Group.

In April, Klaus Ensinger gave up his operational management role and seat on the Ensinger GmbH Management Board. He is, however, continuing to provide support to strategic projects and is a member of supervisory bodies. The Management Board now consists of three people: Dr. Oliver Frey, Ralph Pernizsak and Dr. Roland Reber.

“My decision to leave the Management Board was for personal reasons. One factor was also the desire to have more time in my career for conceptual work and less day-to-day business” is how Klaus Ensinger explained his decision.

In addition, he stressed the intention for the Ensinger Group to remain family-owned in the future. “I still want to contribute to steering the company towards sustainable management worldwide and towards its growth with new products and services”, says Klaus Ensinger.

Polymer expertise in the fight against COVID-19

To boost vaccine production, Solvay, Ensinger and optek are safeguarding the value-added chain with precision components

More than 180 million people have become infected with the coronavirus SARS-CoV-2, which has already mutated multiple times. Effective vaccines have been developed in record time, but billions of vaccine doses are needed to defeat the pandemic. In order to expand production, sensor components – among other things – are urgently required. Sensor bodies – like those produced for optek by Ensinger from a high-performance plastic – enable quality control in the biopharmaceutical process.

“Our sensors detect, for example, the temperature, pH or protein concentration of the liquid”, explains Jürgen Danulat, Managing Director of optek, a company specialising in inline process control solutions. “The component with the measuring interfaces to the medium is complex and difficult to clean. Instead of flow-through assemblies of stainless steel, increased use is therefore being made of what are known as Single Use Cells (S.U.C.), which are disposed of after use. They minimise contamination risks, downtimes and costs associated with chemical cleaning, sterilisation and validation of the plants.”

High dedication to health

“Producing the sensor bodies from medical-grade polymer, glass and metal requires highly precise manufacturing technology. We have all of this expertise and all of these resources in-house”, says Dr. Roland Reber, Managing Director at Ensinger. “But we are dependent on good suppliers like Solvay. We have been fully supported with detailed technical expertise and provided with specific solutions regarding regulatory compliance throughout the whole process.”

“Our value-added services enhance our high-performance polymers and support biopharma processing trends. Radel® PPSU demonstrates how critically important material technologies are to this fast-changing and demanding sector. We take a highly proactive approach to material testing to support regulatory compliance needs”, said Jesal Chopra Vice President - Healthcare, Environment, Consumer, & Construction, Materials Segment at Solvay. Solvay produces the material polyphenylsulfone (PPSU), marketed as Radel®, in different colour shades. The biologically inert resin stands out for its high mechanical, chemical and thermal stability,

and can be cleaned and sterilised using all established methods. At the Ensinger headquarters in Nufringen, the granular material is extruded into stock shapes. Further processing of the sheets and rods with the product name “TECASON P MT” takes place at the Cham site, Bavaria, the Ensinger Group’s largest branch factory.

Top quality – also in partnership

“Here we process engineering plastics into complex parts with extremely narrow tolerances for our customers,” says Fred Nass, who is in charge of Ensinger’s Machined Parts division with its approx. 150 employees. “Starting with stock shapes and injection-moulded parts, we turn and shape the components with the aid of CNC processing centres, check the quality and after cleaning combine them into customised assemblies. We currently, in the cleanroom, configure and package around 100 versions of the sensor bodies for optek sensors as standard.”

Each processing step is precisely documented at Ensinger and the quality continuously checked. “For us this is the same as with end customers from the medical and pharmaceutical fields, or from the aerospace sector: it’s all about premium quality and traceability along the entire value-added chain,” explains Fred Nass. “We benefit here from the fact that process-wise, Ensinger can be a one-stop shop – from raw materials delivery through to customer-specific packaging. We also have a very solid partnership with suppliers and customers. And that pays off in the long term – not just during the COVID pandemic.”

More information

solvay.com/en/chemical-categories/specialtypolymers/healthcare
ensingerplastics.com/en/machining
optek.com/en/biotechnology/single-use.asp

Sales contact

Dominik Schweiger
sales@ensingerplastics.com



The machined parts pass through a rinsing sluce (right) into the cleanroom where they are assembled and packaged. Large items such as the component for a bioreactor shown here are rinsed in a trough with highly purified water.

The machining specialists at the Cham site

Due to the growing demand for high-precision components, Ensinger has invested extensively in the site – even during the coronavirus crisis – , in particular in the Machined Parts division. For example, new CNC processing centres have been set up, the water treatment facility and rinsing stations expanded, and the cleanroom capacities have been almost doubled. This has created additional jobs, with lots of potential for the future.



At Ensinger's Cham site, the high-precision machining of engineering and high-performance plastics takes place.

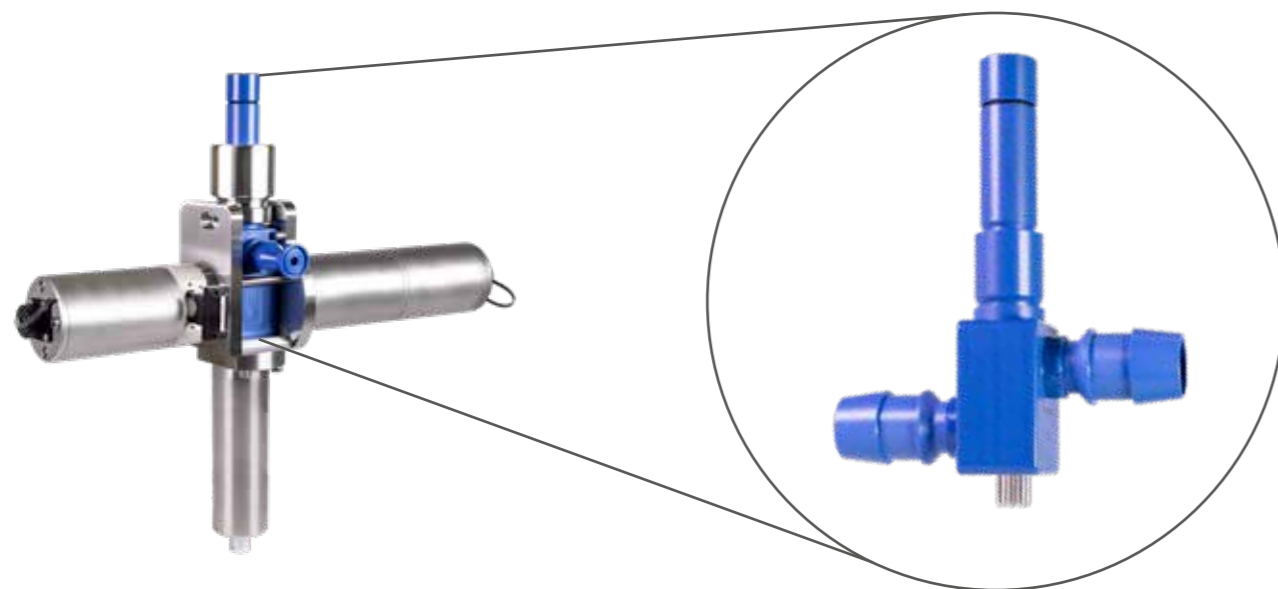

Quality control is extremely important during the production of vaccines and other biopharmaceuticals. Single Use Cells made from special plastic (blue) form the interface between the measurement sensors and the liquid. Photo: optek

COVID-19: Company vaccinations at Cham and Nufringen



The Ensinger team and the Mayor of Nufringen are delighted by the successful launch of the company vaccination drive at the Schwabendlandhalle. In the group photo FLTR: Christian Wöldecke (Head of Quality Management), Marina Pavlovic (Human Resources administrator), Dr. Bertram Schädle (Doctor supervising vaccinations and specialist in emergency medicine), Ingolf Welte (Mayor), Dr. Michael Gehring (Company doctor), Dr. Roland Reber (Managing Director) and Ralph Pernizsak (Managing Director).

Back in April and May, around 250 Ensinger employees at the Cham site were able to benefit from a company vaccination drive. The vaccine doses came from a special allocation for areas close to the border. In June and July, more than 400 employees at the sites of Nufringen and Rottenburg-Ergenzingen received both of their Sars-CoV-2 vaccinations. The venue for the vaccine drive was the Schwabendlandhalle in Nufringen: Right from the start, the team of organisers witnessed high participation levels. “We were able to use all the vaccine doses supplied”, said a pleased Christian Wöldecke, Head of Quality Management and coordinator of the family business’s vaccination drive. This meant that the second

day of vaccinations was available to all those employees who had not yet received a vaccine. “As an employer, we regard it as our responsibility to use all options available to us for controlling the pandemic. So on the Management Board, we view it very positively that our employees are taking up this offer”, said Ralph Pernizsak, reporting from the venue. “I am very grateful to Ingolf Welte, the Mayor of Nufringen. And such a vaccination drive can only be implemented if lots of volunteers are available to help alongside the medical staff. The organisation and infrastructure in the Schwabendlandhalle is perfect - the doctors supervising vaccinations have confirmed this. Our thanks also go to Mr Wöldecke

and his team, and to Mrs Pavlovic from the Human Resources department, who dealt with the issuing of invitations.” It was Ingolf Welte’s initiative to have a joint vaccination centre which could be used both by local residents and by the companies in the business park. “As Mayor, I am delighted that we were able to support our biggest local employer by setting up a vaccination centre”, said Welte at a meeting with Ensinger’s Management Board. Dr. Roland Reber confirmed the importance of COVID-19 vaccinations and rapid tests for a manufacturing company. “We are all aware that there is always the possibility of becoming infected either within or outside of the company. If several staff members in key positions have to go into quarantine, then in the worst case this may cause several days’ interruption to business. COVID-19 remains a life-threatening illness, so we are glad that a large proportion of our employees at the Nufringen, Ergenzingen and Cham sites have been vaccinated”, emphasized Dr. Reber.



Dr. Michael Gehring, Company doctor at Ensinger in Nufringen, vaccinates an employee from the Shapes division.

A warm welcome ...

Employees who have joined Ensinger GmbH from January to August 2021

Nufringen

Compounds

Eugen Borgeno
Rilind Gjyliqi

Industrial Profiles & Tubes

Johannes Maier
Holger Schönhuth
Ingolf Streubel
Philipp Unger

IT

Tim Hellstern

Marketing

Selina Anke

Shapes

Serkan Ayvaz
Haseeb Chaudhry
Valentin Feige
Olivia Garyantesiewicz
Sven Häfner
Tahsin Ilhan
Claudia Ininger
Dennis Korbel

Marek Kozak

Philipp Lang
Medina Mujanic
Alexander Postolenko
Lena Reichardt
Julian Reizer
Anna Roll
Manuel Ruf
Amy Schäfer
Patrick Schindler
Jessica Schneider
Kubilay Sigwarth
Sibel Süzoglu
Norbert Vötsch
Steffen Weber
Sebastian Wizemann
Desiree Zens

Ergenzingen

Injection Moulding

Jessica Beierle
Aleksandr Cudakov
Oliver Stiegen
Jasmin Vollmer

Cham

HR

Arne Walter

insulbar

Sandra Benda
Bianca Breu
Zdenek Cermak
Petr Gaip
Julian Göttlinger
Robin Gruber
Josef Höcherl
Björn Höppner
Uli Kagermeier
Anna Kubernat
Florian Lippert
Kevin Mehrbrodt
Christian Rötzer
Patrik Ruzek
Eva Semotanova
Vaclav Tichacek
Michala Vikonova
Jan Vlk
Max Walther
Andreas Werner
Jasmin Wolf

Machined Parts

Erika Babati
Elena Barbu
Galina Grak
Maximilian Hruschka
Ingrid Ketterl
Nico Kiefl
Verena Kulzer
Alexander Ley
Tobias Niermeier

Technical Management

Markus Heigl

Tooling

Patrick Breu

Administration

Christina Hauck

With the best thanks ...

This year the following employees celebrate their company anniversaries at Ensinger GmbH:

25

Nufringen

Ralph Kapitel
Rüdiger Kiefer

Vanessa Kinsky
Gottfried Peschka
Christian Sabo
Ali Say
Bernd Widmann
Horst Wolf

Ergenzingen

Jürgen Fischer

Cham

Werner Bachl
Andreas Breu

Ulrich Heinze
Martin Heyes
Andreas Roider
Stefan Schirrmacher
Manfred Schmaderer
Ronald Tremmel

Virtual Showroom replaces physical trade fair

What is one to do if important industry trade fairs are cancelled or are only taking place online because of the pandemic, but the list of innovations is long one and there is a big need to present these to the customers? For our construction products related to insulbar, the solution was a virtual Showroom.

For months on end, the insulbar team worked flat out to set up a suitable digital trade fair stand. They first had to draw up a basic concept, and create the technical environment. The next step was designing the layout, and then finally filling it with the Showroom content. Lots of new formats were developed for the content, such as product clips, video statements and infographics. A mailshot, PR and advertising campaign targeting a wide audience informed (potential) customers of the Showroom launch date. And to make sure everything ran smoothly during the trade fair event, all Sales staff were ultimately trained to use the new environment.

Première simultaneous to BAU 2021 fair

In January, parallel to the digital BAU 2021 fair, the time had come. The insulbar team invited (potential) customers to explore the new insulbar world, and many took up the offer. In numerous video live chats and meetings, discussions were held, products presented and joint browsing of the virtual trade fair took place. And for visitors who made a spontaneous visit to the Showroom, colleagues were present at all times to answer any questions they happened to have. There was also a 'date' with international trade press representatives in the form of two digital press conferences. With totally new products and established solutions, there was lots for the visitors to discover when it came to the efficient insulation of windows, doors and façades made from metal. The primary focus here was on our sustainable insulbar insulating profiles from unmixed, recycled PA 66.

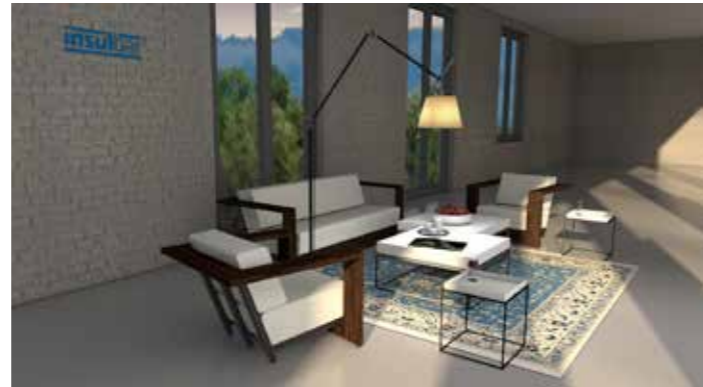

Throughout the trade fair, Ensinger employees are available in the Showroom lounge to answer all the visitors' questions in live video chats.

insulbar 24/7

Hopefully we will soon be able to present our diverse products, solutions and ideas to you in person at physical trade fairs. But regardless of this, our virtual Showroom is staying open. 24 hours a day, 7 days a week, anyone interested can explore insulbar products in peace and quiet, find contact persons and arrange appointments.

Why not give it a click!

showroom.insulbar.com



Trade fair slogan: the digital appearance was all about sustainability and environmentally friendly insulbar products from recycled PA 66.



Visitors can find out about Ensinger and insulbar at several different pylons and touch points.

SC21 Award: Recognition for Ensinger Machined Parts

For the second year running, the Bridgwater facility of the British subsidiary Ensinger Machined Parts has received the Bronze award in "Supply Chains for the 21st Century".

The SC21 programme is designed to strengthen the supply chains of the aerospace industry and the defence sector in the United Kingdom. The competition reflects the high standards of these technically demanding industries.

Ensinger's machining companies in the United Kingdom have now been combined into one brand. The trading name of Bridgwater-based Trig Engineering Limited had already been formally changed to Ensinger Machined Parts Limited, and on 1 April the new company acquired the assets of Ensinger Precision Engineering Limited (EPE, Tonyrefail). The merged machining company now has two sites in Wales and England and is operating under the name Ensinger Machined Parts Limited.



Ensinger Machined Parts – 24/7: The robot cell permits the efficient machining of high-precision components.



Closure of the Anröchte sales branch

On 30 June, the Shapes division closed its sales office located in Anröchte, North Rhine-Westphalia. As communicated nine months ago, the sales activities at the site were merged with those of the Nufingen site. Five colleagues are affected by the site closure.

"This was not an easy decision for us. But the previous distribution of tasks had resulted in the duplication of effort in many areas. The new, centralised structure considerably improves processes.

service we provide to our stock shapes customers", explained Ralph Pernizsak.

The office in Anröchte was opened in 1989. Because a transfer to Nufingen – far away from their native region of the Sauerland – was not an option, the five sales colleagues all accepted the voluntary redundancy offered. To help support the transition to a new job, Ensinger is paying for professional outplacement advice for the colleagues leaving us.

Innovative LDS technology replaces silicon wafers

Lithography-free manufacture of sensors and microsystems

The market for sensor applications is a big one: large numbers of microsystems are used in the IT and telecommunications sector, the automotive and aerospace industries, and mechanical and plant engineering. These electronic components are based on 'wafers' – thin slices of material, usually silicon, onto which thin films are applied. The production and further processing of silicon wafers is very labour-intensive and costly. The Institute of Micro Production Technology, part of the Leibnitz University Hannover (IMPT), has investigated alternative production methods for sensor applications. A study showed that modified polyetheretherketone (PEEK) can replace high-cost substrates such as silicon. To make a function demonstrator (temperature and magnetic field sensor) using injection moulding with laser direct structuring (LDS), the material TECACOMP PEEK LDS black 1047045 – a high-performance compound from Ensinger – was used.

Injection moulding and laser direct structuring: three production steps instead of seven

The production of an enclosed sensor which can be easily integrated into assembly processes for printed circuit boards comprises, with the LDS method, three production steps:

In the first step, the substrates are produced from laser-activatable plastic in an injection moulding process. This incorporates predefined sensor structures as well as vertical interconnect accesses (VIAs) for through-connections. The next step is the laser drilling of recesses and the activation

of the LDS-compatible polymer by means of current-free, selective precipitation of metals. Subsequently an unstructured sensor layer is applied by means of cathode sputtering. The required structures are then exposed in a CMP process (chemical mechanical polishing).

Using injection moulding with laser direct structuring reduces the complexity in

manufacturing and packaging processes. Unlike conventional silicon-based wafer production, the LDS method does not require a cleanroom environment or photolithography.

Thermoplastics permit affordable sensor production

As well as reducing the number of process

steps, the use of laser-activatable high-performance polymers instead of silicon as a substrate for wafer manufacture can also bring significant cost benefits for production. Stefan Bur, Application Segment Manager for MID/LDS at Ensinger, sees huge potential in this innovative application: "In the electronics sector, the polymer PEEK in particular is becoming increasingly important thanks to its special properties. The study by the IMPT has shown that our compound TECACOMP PEEK LDS, which is unique on the market, can be used as a wafer material. In initial applications, the sensor displayed around 75 percent of the performance capacity of a conventional, silicon-based sensor. The manufacturing costs showed potential savings of 90 percent." Ensinger is confident that in the future, small and medium-sized companies will also be in a position to produce cost-effective wafers for microsystem technology using the LDS method. "For this reason we are investing in the development of these compounds. Our new product, TECACOMP PEEK LDS grey, is already optimised for applications that place particularly high demands on surfaces", explains Stefan Bur. The light inherent colour of the "grey" type allows colouring by batch during injection moulding. This means that a colour variation is possible even with small quantities.

Fields of application

TECACOMP PEEK LDS compounds may be of interest for sensors in electrical engineering, mechanical engineering and medical technology. Potential areas of application are position sensors (AMR and GMR sensors), eddy current sensors, tem-

perature sensors for measurements in the laboratory or industrial processes (thin-film Pt sensors), or DC converters.

Property profile: TECACOMP PEEK LDS black 1047045 compound

When it comes to manufacturing microsystems, the LDS makes particularly high demands of the polymer. For many years now, Ensinger has been developing thermoplastic compounds for laser direct structuring and is currently the only plastics specialist who can offer a PEEK certified for the LDS method by LPKF Laser & Electronics AG. TECACOMP PEEK LDS black 1047045 is optimised with mineral fillers. The material is extremely temperature-resistant (up to 260 °C, long-term), has very good weld strength, good adhesive strength and shows high chemical resistance to solvents. Furthermore, TECACOMP PEEK LDS has a very low coefficient of linear thermal expansion - one which is closer to that of metals than that of many other plastics.

More information

ensingerplastics.com/en/compounds/laser-structuring

Sales contact

Stefan Bur
stefan.bur@ensingerplastics.com



The illustration shows microstructures (Bragg grating) on a sensor. The compound TECACOMP PEEK LDS black 1047045 made by Ensinger is extremely temperature-resistant, has very good weld line strength, good adhesive strength and shows very high chemical resistance to solvents. Furthermore, the material has a very low coefficient of linear thermal expansion. Photo: Ensinger / IMPT

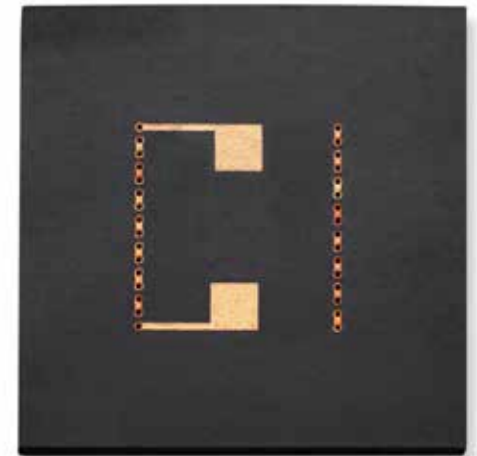

Magnetic field sensor, manufactured by means of injection moulding with laser direct structuring (LDS). The substrate used is the high-performance polymer TECACOMP PEEK LDS black 1047045 from Ensinger. Photo: Ensinger / IMPT

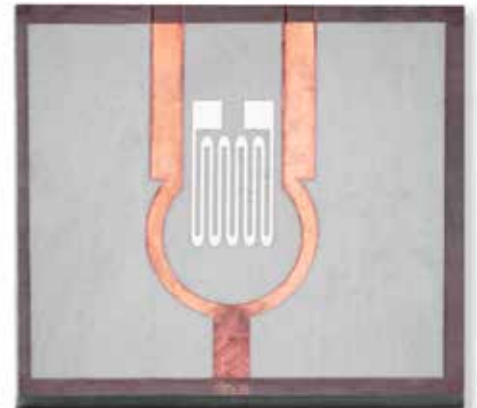

Eddy current sensor. For its manufacture by means of the LDS method, the compound TECACOMP PEEK LDS grey is used. This new product variant from plastics processor Ensinger fulfils particularly high surface requirements. Photo: Ensinger / IMPT

SAP and CRM roll-out in Denmark

Not just any old project. Or "ja, vi gjorde det!"* – by Jochen Genterczewsky, Head of Business Solutions

As of this year, Denmark is no longer famous only for its smørrebrød and hygge, but is establishing a milestone in the IT history of our company. On 1 April, Ensinger Denmark was the first foreign subsidiary to be integrated in the centralised SAP and CRM system.

Now, our Danish colleagues are working on the same platforms as the GmbH in Germany. These processes include the preparation of quotations, sales orders, logistics bookings, the conversion service and accounting. Thanks to the SAP integration, we have high transparency of warehouse stocks, requirements and key figures. The orders from Denmark to Nufringen can now be efficiently processed in one system.

Remote control only

Circumstances, however, were anything but ideal. Preparations were commenced by the team in late summer 2020 – a time in which all those involved were struggling with short-time working, Covid restrictions and a scarcity of resources. Among other things, we had to cancel our planned trip to Denmark two days before take-off and were also not able to be present during any of the project phase. The project ran in "remote-only" form via Microsoft Teams or screen sharing. For areas such as the Conversion Service or Logistics, this constituted a particular challenge, since in these cases SAP implementation depends on optimum application of the system to the local conditions.



German-Danish cooperation: Go-live in the conversion service.

Thanks to the tireless efforts by the German and Danish key users and with the support of the colleagues from the IT Service Center, the specialists completed the switchover successfully.

A massive thank you, or "TAK", to all those involved – with this roll-out we have established a basis for further SAP and CRM roll-outs in the coming years and we are looking forward to future projects which will hopefully not be happening under pandemic conditions but in normal form.

**Yes, we did it!"

Awards for outstanding achievements

The aim of the Wilfried and Martha Ensinger Foundation is to support social, scientific and cultural projects in the long term. One of the Foundation's priorities is

promoting new talent. At Ensinger, those who have completed their vocational training or an integrated degree programme with top results are awarded a Wilfried

Enginger prize. At institutes of higher education, the Foundation recognises outstanding Bachelor's, Master's and PhD theses.

Two award ceremonies in Nufringen



In July a total of four former apprentices were recognised for their particular achievements. Wilfried Ensinger (5th from left) did the honours together with Edith Holzberger (4th from right) in Nufringen. Wilfried Ensinger prizes went to Paul Vincent Theurer (toolmaker, left), Tim Hellstern (IT specialist for system integration, 3rd from left), Valentin Feige (process mechanic, 3rd from right) and Benjamin Preuß (process mechanic, right). The company founder and benefactor congratulated those who had successfully completed their apprenticeships and thanked everyone who had supported them. At the photo shoot, the team of instructors was represented by Marcel Kurz (2nd from left), Michael Wende (4th from left), Miriam Fiedler (5th from right) and Andreas Schweikert (2nd from right).

Following his apprenticeship, Valentin Feige was taken on by the Shapes division as a machine setter, Benjamin Preuß and Paul Vincent Theurer are now attending an institute of further education, and Tim Hellstern has joined the IT Service-Center as a system engineer.



Johannes Maier received a Wilfried Ensinger prize for his outstanding achievements in his toolmaker apprenticeship. Edith Holzberger, Chairwoman of the Wilfried and Martha Ensinger Foundation, presented the award in March. Since then, Johannes Maier has been working for the Industrial Profiles & Tubes division.

The system proves its worth



Four years ago, the ERP system SAP was introduced at Ensinger GmbH. Now, more and more divisions and countries are working on this platform on a daily basis. Since the roll-out, the key users and IT have carried out several hundred optimisations. Lots of new functions have been introduced, for example linking to haulage firms and supplier assessment, production planning optimisers, or integrated tool planning. Further modules are to follow, each of them aimed at further improving the transparency and efficiency of processes. These factors enable Ensinger to respond better and faster to customer requirements.

Wilfried Ensinger prizes awarded at the Institute of Plastics Technology (IKT)

Every year at the University of Stuttgart, the Wilfried and Martha Ensinger Foundation gives recognition to outstanding Master's and PhD theses. The Wilfried Ensinger prizes, which are worth 3,000 and 2,000 euros, were presented to Dr. Alexander Geyer and Felix Grauf in March. Both scientists produced their theses at the Institute of Plastics Technology (Institut für Kunststofftechnik, IKT). Dr. Geyer's dissertation is entitled: "Inline characterisation of plastics within the injection moulding process and their potential in the context of self-learning machines." Felix Grauf's Master's thesis deals with shear and extensional viscosities of plastic melts that contain blowing agents.

ikt.uni-stuttgart.de

Graduation ceremony at the Cham Technology Campus

At the end of July, the graduates of the Bachelor's integrated degree programme in Mechatronics were bid farewell in an official ceremony at the Cham Technology Campus Matthias Eigenstetter was awarded the Wilfried Ensinger prize (1,000 euros) for his Bachelor's thesis.

th-deg.de/de/tc-cham



Satellite components from high-temperature polymer

Since October 2017, the satellite Sentinel-5 Precursor has been circling the earth in low Earth orbit – at altitudes of between 808 km and 848 km – as part of the ESA's "Copernicus" mission. It is spending seven years gathering important data on trace gases and aerosol which affect air quality and the climate. Also on board the satellite are specially designed bearings manufactured from non-meltable polyimide by Ensinger Sintimid.

Weight-saving, simple design

Sentinel-5P is equipped with three collapsible solar modules, which have been developed and constructed by SpaceTech. The aerospace company from Immenstaad by Lake Constance paid particular attention to the mechanism for unfolding the solar panels and the associated bearings. The intention was to reduce its components to a minimum in order to keep the payload as low as possible. Conventional roller bearings such as ball bearings would have made the design very complex and heavy. In addition, the bearing needed to enable an unfolding motion of the panels at any

angle as well as precise fixing. SpaceTech solved this problem by designing a tapered slide bearing which works in a similar way to a shoulder joint socket.

Tough demands on the material

Materials used in space travel must withstand extreme stresses. Hence the material of the slide bearing also has to fulfil tough requirements: It was important to prevent cold welding resulting from vibrations during the launch and when the solar module is extended, and likewise to avoid deformations due to high dynamic loads during the flight phase. The polyimide TECASINT 2391 from Ensinger Sintimid was the only material – with its low creep tendency and low static and slide friction coefficients under the conditions found in space – to meet the requirements for a low-energy, efficient and weight-saving drive mechanism.

